

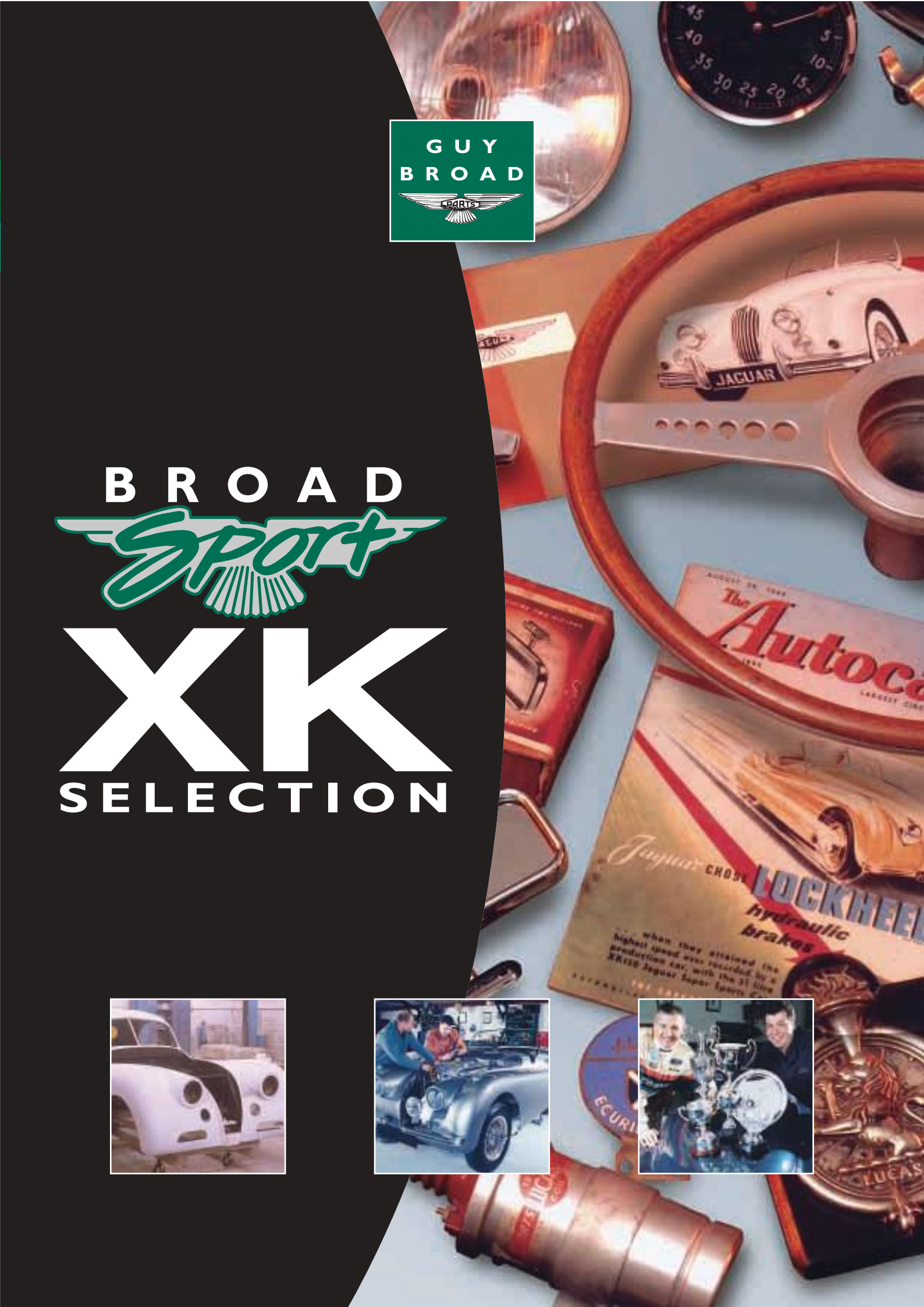

BROAD
Sport
XK
SELECTION



FIFTY YEARS ON, YOU CAN BUY A BRAND NEW XK AGAIN!

A brand new workshop-fresh Jaguar XK, fully equipped, finely tuned and ready for the road, or the racetrack, for that matter. These new-build BroadSport XKs are built to satisfy your dream of a lifetime.

You choose the specification to suit your lifestyle. Relaxed continental touring, club outings or fast-paced competition. A BroadSport XK is whatever you want it to be, and much more besides.

The log book and registration authenticate the provenance of your cherished classic. It loses nothing of its heritage or originality, but gains



superior performance, handling and safety to match today's critical motoring needs, and probably increases in value too!

BroadSport-developed components, tried and tested in hard-won competitive events by our own racing teams, add new levels of vitality and safety standards. Nothing is overlooked. Engines, gearboxes and drive trains, cooling, brakes, suspension, wheels, tyres and steering, are all testimony to the latest developments in technical excellence.

It's amazing what half a century of technical innovation and limitless BroadSport expertise can add to an original classic!



A handwritten signature in black ink that reads 'Guy Broad'.

CONTENTS



1

ENGINE

2

CARBURETTORS, FILTERS & EXHAUSTS

3

GEAR BOX & DRIVE TRAIN

4

FUEL



5

COOLING



6

BRAKES

7

SUSPENSION, WHEELS, TYRES & STEERING

8

ELECTRICAL



9

INTERIOR & EXTERIOR FITTINGS

10

ACCESSORIES

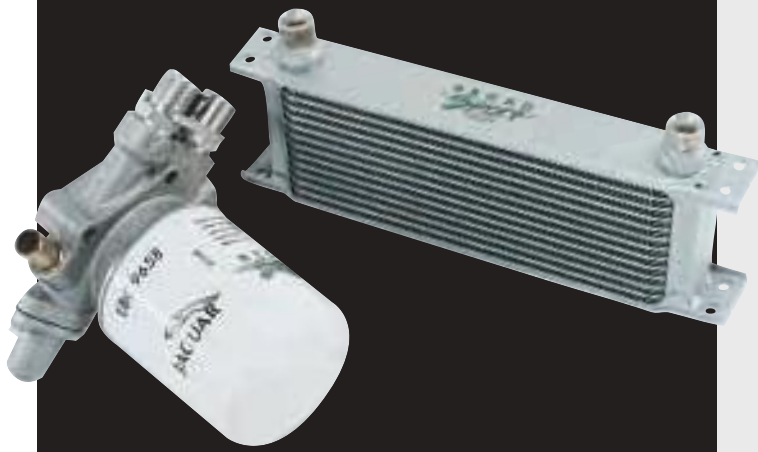

BROAD
Sport
XK
SELECTION



*Left: John Broad
 National Hill Climb,
 Shelsley Walsh June 1956*



*Above: Guy Broad at the
 wheel
 Left: Jeremy Broad
 Aston Martin Club
 Meeting, Silverstone
 July 1976*

Welcome to the BroadSport XK Selection performance parts catalogue.

We've come a fair distance since the first edition rolled off the presses nearly ten years ago. Thousands of copies have found their way around the world and requests continue to pour in from XK enthusiasts eager to find out what's new from BroadSport. It's actually become a collectable item!

Here you'll find the very latest BroadSport performance goodies from our component development team, each tested and proven in our own cars. Regular product information sheets will keep you right up-to-the-minute with new arrivals – keep them in the wallet pocket on the inside back cover.

Ordering is easy. From the moment you contact us you're dealing with an expert who understands XKs through and through. We'll help you find exactly what you want, advise on new developments or technology that we feel will best meet your particular needs and supply (or fit, if you wish) the complete BroadSport performance package.

The parts can be tailored to suit your car's particular specification, and ready for immediate despatch wherever you may be.



We can also service your XK, or rebuild or refurbish any neglected examples that might still be languishing under covers. The BroadSport team regards it as a privilege to keep your Big Cat in good health and looking good.

In addition to the BroadSport XK Selection catalogue, our individual XK120, 140 and 150 parts catalogues detail the many thousands of parts you'll need to keep your XK in tip-top running order.

Joining them are Engine Parts Catalogues and "Top Secret" catalogue. Plenty of words of wisdom in all of these!

Call us now for your free copy.

PARTS HOTLINE
01676 541980
FAX: 01676 542427



ENGINE

An XK in full song is a sound to gladden the heart of anyone who cherishes engineering excellence. And it's a purr that begins in the heart of the Cat herself. Guy Broad Parts will recondition any XK engine for touring reliability or to full competition specification. We also offer a range of modifications - including conversion for lead-free fuel, gas flowing, polishing and balancing.

1



ENGINE RECONDITIONING SERVICE

From standard road to full race specification, we can offer a range of modifications including lead-free conversion, gas flowing, polishing and balancing. We use the latest methods and products to achieve very high standards to 'show' quality.

Part No. **ENQUIRE**



ENGINE

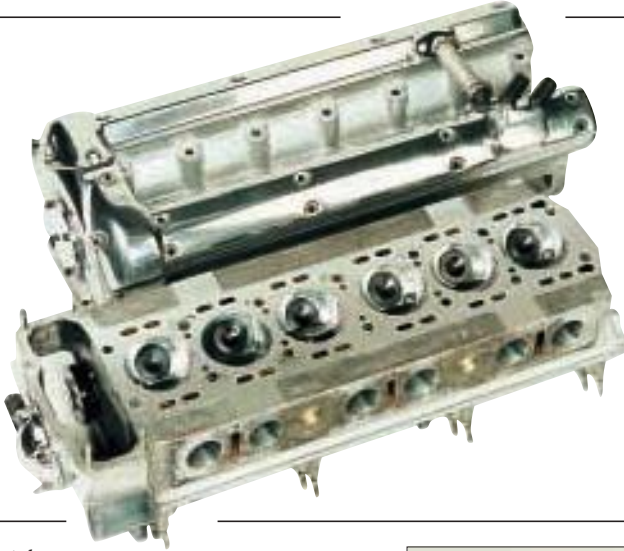

CYLINDER HEAD RECONDITIONING

We can restore cylinder heads to standard or race specification with lead-free valve seats, porting and polishing. We can also weld and machine badly corroded water-ways. Heads are available assembled and ready to fit.

Part No. **ENQUIRE**

Right:

1. Type C cam covers reconditioned, polished and ready to fit.

Part No. **ENQUIRE**

2. Le Mans type quick-release oil filler cap and threaded adapter.

Part No. **FC3**

3. Type C cam cover badges, including studs and nuts for easy fitting.

Part No. **C9099**

4. Le Mans type plug lead spacer block. As original on D type in Tuffnol material.

Part No. **PLBI**

4a. As above in polished alloy

Part No. **PLBIA**
(see page 21 for picture)



Right:

5. D type specification cam covers. As original or to customers own requirements for dry or wet sump lubrication.

Part No. **DCC**



Right:

6. High output oil pump and large bore pick-up pipe. For maximum oil delivery to update any 140/150 engine.

Part No. **OP63 & C8606R (140)**
OP63 & C12939R (150)

7. 120 oil pump reconditioning, using new gears and drive shaft to bring the pump back to factory specification.

Part No. **C4715E**

8. XK rear crank oil seal conversion. Simple fitting with no machining necessary. All hardware included, ready to fit.

Part No. **GMBI I**



Lower right:

9. Composite head gasket for 3.4 or 3.8 litre engines. Also aids cylinder heads that have been skimmed several times. Bore sizes needed when ordering.

Part No. **CHG1 (3.8)**
CHG2 (3.4)

10. High tensile cylinder head studs. A must for any high compression engine.

Part No. **VHSI**

11. Valves available for any application and specification. Also in stainless steel.

Part No. **ENQUIRE**

12. Core plug strapping kit, including drill and tap.

Part No. **CPSK**



ENGINE

Right:

13. Crankshaft reconditioning service available to race specification. Nitrided, polished and balanced or, of course, standard.

Part No. **ENQUIRE**

14. Con Rods available. New wide blade type polished and balanced, if requested.

Part No. **C7917S**

15. Full race specification vibration damper. The finest available.

Part No. **RCD100**

16. Standard crank damper reconditioned with a new type polymer rubber to our specification.

Part No. **C15274E**

17. High compression forged pistons available in various over sizes and measurements. For high RPM use only.

Part No. **ENQUIRE**



Left:

18. Competition clutch assembly. 9/16 inch diaphragm type heavy duty.

Note: You will need to re-drill the standard XK flywheel to use this clutch.

Part No. **HDC3P**

19. 132 teeth XK flywheel ring gear.

Part No. **C4809RG**

20. Full race flywheel for 7/16 inch triple plate clutch. For the serious racer only.

Part No. **C4809RACE**

21. Lightened, balanced and double drilled flywheels always in stock for exchange.

Part No. **C4809E/I**

Right:

22. Fast road/rally camshafts. Sold on exchange basis for extra mid-range punch. Various specifications for road/rally/race.

Part No. **JAG4**

23. Tappet guide hold down kit. For exhaust tappet guides when engine is used in extreme conditions and high temperatures.

Part No. **TGHD**

Below:

24. Alloy oil catch tank. Correct size for Jaguar engines. Available with single or twin inlet holes, built-in sight gauge and drain-plug. Overall size - 19cm x 23cm.

Part No. **Single inlet tank OCT1**

Twin inlet tank OCT2



Left:

25. Engine mounts by 'Metalastik'. Very high quality and now tested on 300 bhp engines! Still with no sag or deterioration to the rubber. The best does not come cheap!

Part No. **C4794HD**

PARTS HOTLINE
01676 541980
FAX: 01676 542427



2

CARBURETTORS, FILTERS & EXHAUSTS

Fuel injection and computerised engine management make a cold start so predictable these days. With total authenticity, we can help you re-capture the balmy days of tickling the carb until it fed precisely the mix your XK relished. And on the subject of turning petrol into raw power, why not make it all flow better with a C-type Weber kit.



1. XK140 and C type 2 inch SU carburetors as fitted originally to these specially ordered cars. Faithful reproduction with all linkage and fittings.

Part No. **C7096**

2. Correct fuel feed rail for above carburetors.

Part No. **C7289**

3. Correct coil mounting bracket for 2 inch carburetors.

Part No. **C9129**

4. Original specification 'AC' air filter as fitted to XK140 with 2 inch carburetors.

Part No. **C8484**

4a. Stainless steel air filter 1 3/4".

Part No. **PAC1**

4b. Stainless steel air filter 2".

Part No. **PAC2**



CARBURETTORS, FILTERS & EXHAUSTS



Left:

5. Carburetor reconditioning service to concours specification. We have all types in stock for exchange service.

Part No. **ENQUIRE**

6. SU jet adjuster tool kit. A must for all H type SU carburetors.

Part No. **AUE670**

7. New carburetor overflow pipes for the right finishing touch.

Part No. **CI2280**

Right:

8. Weber manifold and linkage set to suit 40 or 45 DCOE Webers.

Note: Fits straight-port heads only.

Part No. **WEBER1**

9. 45 DCOE Weber to suit the above manifold.

Part No. **45DCOE**

10. Special C type Weber manifold as originally fitted to Le Mans cars. Can be supplied as illustrated or fully assembled with water rail and studs.

Part No. **WEBER2**

10a. K & N 45 Weber filter assembly. Three per set. Washable and very high quality.

Part No. **KN45**

Below:

11. Cast alloy trumpets for 2 inch SU carburetors. Superb quality. Race specification.

Part No. **RP25**

12. Short alloy trumpets with mesh covers. Lightweight spun alloy for road or race, for 2 inch carburetors.

Part No. **RP2**

13. As above but for 1 1/4 inch H6 type carburetors.

Part No. **RPI**

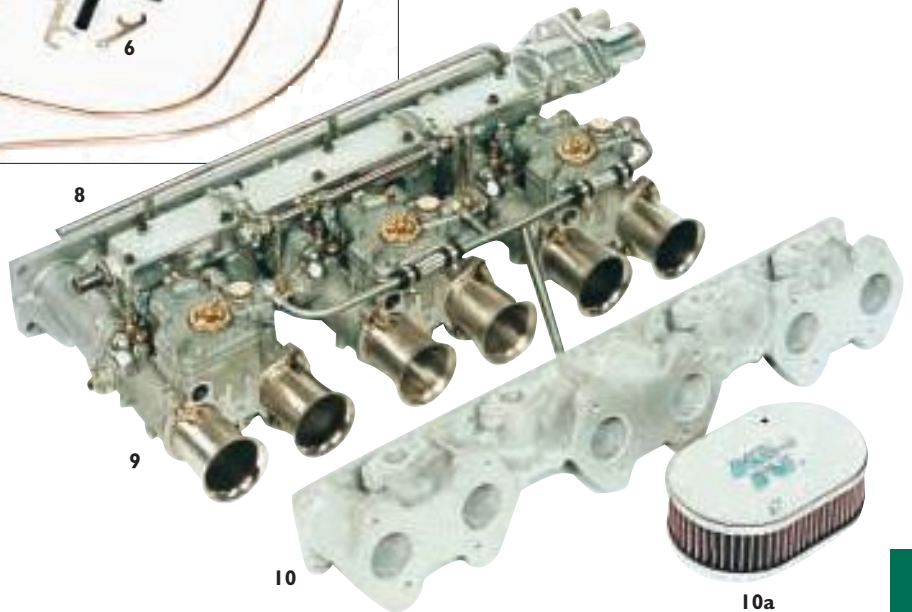

Below:

14. Replacement air cleaner for XK140 DHC, FHC and all 150 LHD twin carburetor cars. Looks as per original but with a replaceable paper filter element.

Part No. **CI3069RE**

15. Paper replacement filter for above.

Part No. **GFE1003**

16. XK150 'S' triple carburetor air cleaner box. Correct copy of original unit.

Part No. **CI5277**

17. Foam washable filter for the above unit eliminates even the finest dust.

Part No. **CI5258**



Above:

18. Heat resistant wrap. Suitable for all types of exhaust manifolds. Reduces underbonnet temperatures easily.

Part No. **HRW**

19. Filter socks. (Rampipe not included)

Part No. **1052**



PARTS HOTLINE
01676 541980
FAX: 01676 542427

2

CARBURETTORS, FILTERS & EXHAUSTS

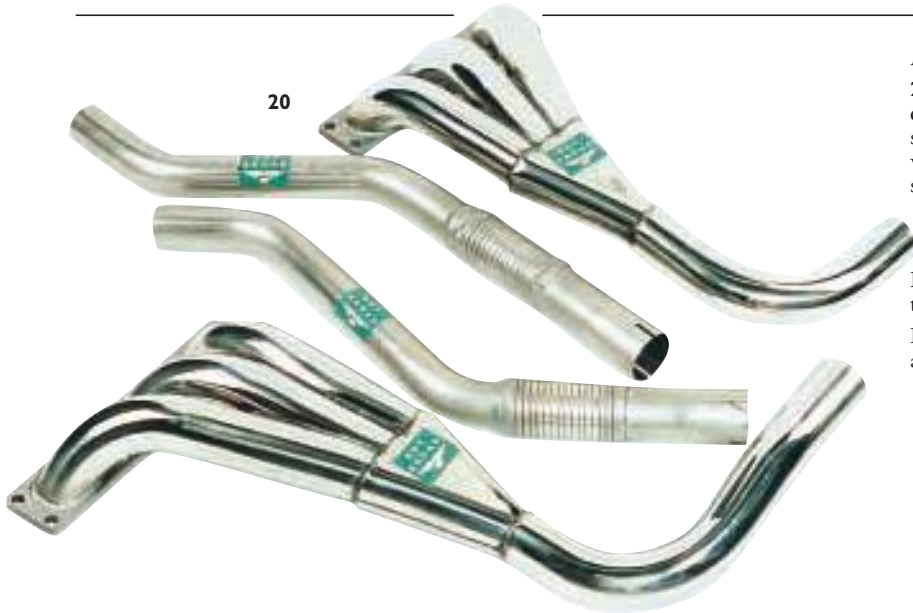

Left:

20. Six branch competition type exhaust manifolds in polished stainless steel, with interconnecting pipes so it will fit to your existing original type system.

Part No. **JR3020-3 (120)**
JR3030-5 (140/150)

Price is per car set of two manifolds and two intermediate pipes.

Full straight through systems also available.

2



BROAD SPORT



Restoration is all about authenticity. But if you plan to open your car up on the road or on the circuits then you must turn to modern technology to protect the car and the driver, as well as sharpen performance.

Matching a precise package of performance parts to your car is what BroadSport is all about. Ring us and talk about it.



PARTS HOTLINE
01676 541980
FAX: 01676 542427



GEAR BOX & DRIVE TRAIN

3

Recreating a dinosaur from its DNA is a doddle compared to rebuilding an original XK gearbox. But happily, we have a hoard of old boxes to cannibalise and give yours an even chance of survival. We have less trouble in supplying authentic specs for other links in your drive train - even the most vital part of all, an authentic, original XK gearknob.

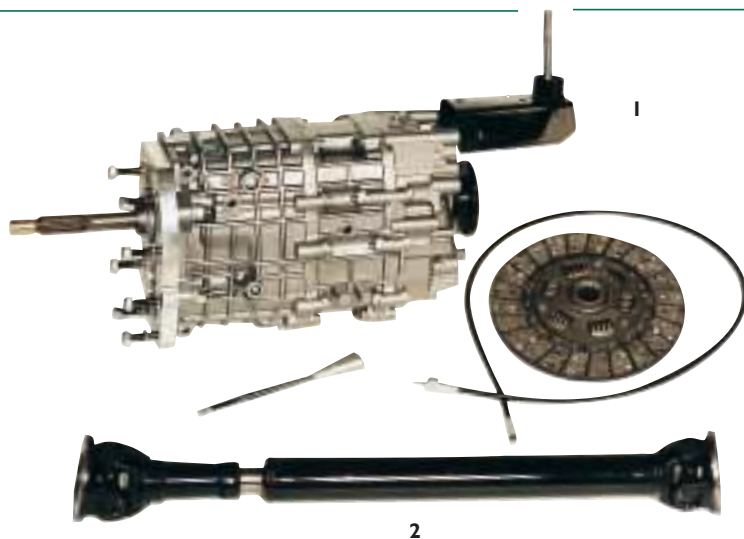

1. Five speed gearbox conversion.
Getrag unit and necessary components to fit any XK bell housing. The basic kit includes spigot bush, speedo cable and gear lever assembly. The XK120 kit also includes a rear gearbox mounting and brackets.

Part No. **GETRAG1 - 120**
GETRAG2 - 140/150

2. New remade propshafts, balanced.
Available for all XK combinations and Getrag conversions.

Part No. **GP2 for 140/150**
GP3 for 120



GEAR BOX AND DRIVE TRAIN

Right:

3. Gearbox rebuilding service. Original XK gearboxes are very difficult to rebuild and internals have now become almost extinct. We have many old units that allow us the best possible chance to rebuild customers own units.

Part No. **ENQUIRE**

4. Overdrive reconditioning service for all types of Laycock units for exchange from stock.

Part No. **ENQUIRE**

5. Gaskets, seals, bearings and shafts. All parts to service XK units.

Part No. **ENQUIRE**

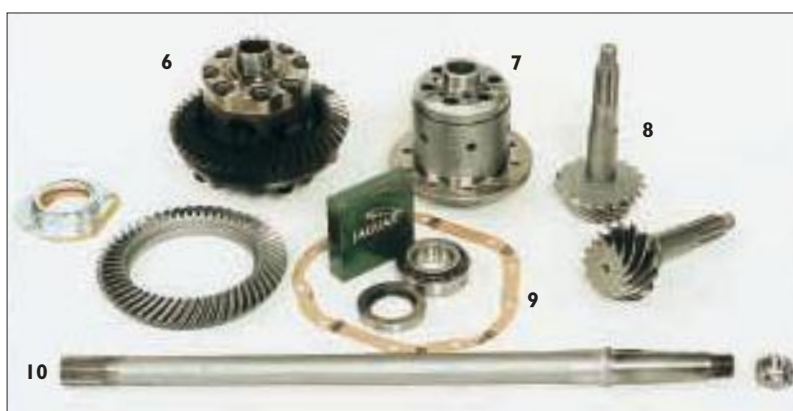
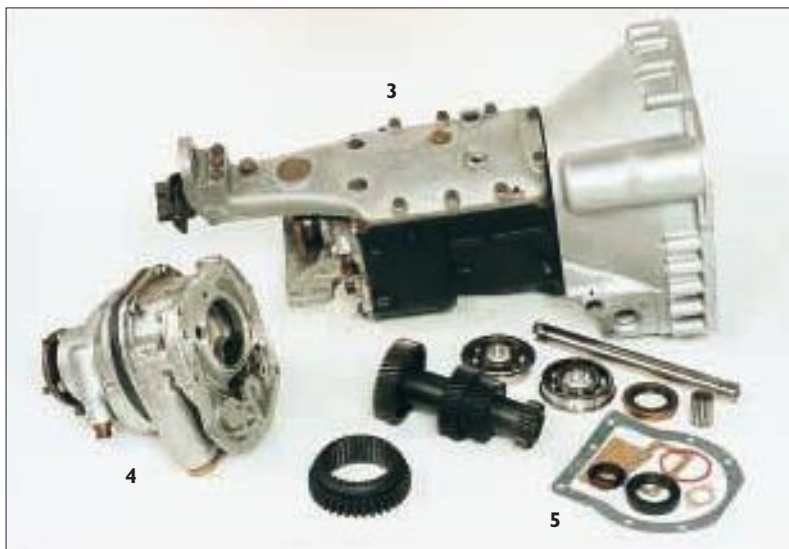

Left:

6. Salisbury 'Power Lok' differential units. We can install and recondition to any type of specification and use. Available from stock.

Part No. **ENQUIRE**

7. 'Quaife' limited slip differential for rally or race use. The best unit in the business for serious competition use.

Part No. **QUAIFE**

8. Crown wheels and pinions of various ratios that can be built into any Salisbury axle to suit any needs of road, rally or race use.

Part No. **ENQUIRE**

9. All servicing and rebuilding components for axles held in stock.

Part No. **ENQUIRE**

10. New axle shafts made from heat-treated EN24T nitrided steel fully machined. The only way to own straight unbreakable axles.

Part No. **3924**

Right:

11. Correct original type XK gearknob.

Part No. **C2291**

12. 3.8 E type and late XK150 gearknob.

Part No. **C16154**

13. Alloy C and D type style gearknob.

Part No. **AGKI**

14. Gear lever and alloy gearknob with integral overdrive switch for fast overdrive change on rally cars.

Part No. **1B3736**

15. Propshaft yoke for replacing worn or damaged units.

Part No. **12**

16. Propshaft universal joints, correct size with grease nipple. Top quality only.

Part No. **46**

17. As stated before, brand new balanced propshafts. The only way to ensure an overall 'smooth' feel.

Part No. **ENQUIRE**

18. Alloy diff cover to suit Salisbury 4HA axles.

Part No. **ADC**



PARTS HOTLINE
01676 541980
FAX: 01676 542427



FUEL

This is where you'll find the glass fuel bowl and filter assembly that's spot on period for an XK150 'S' or indeed any XK. Or perhaps it would suit you to lighten the load and fit an alloy 120 fuel tank in place of the standard steel type. Stronger and safer if anything - and half the weight.

4

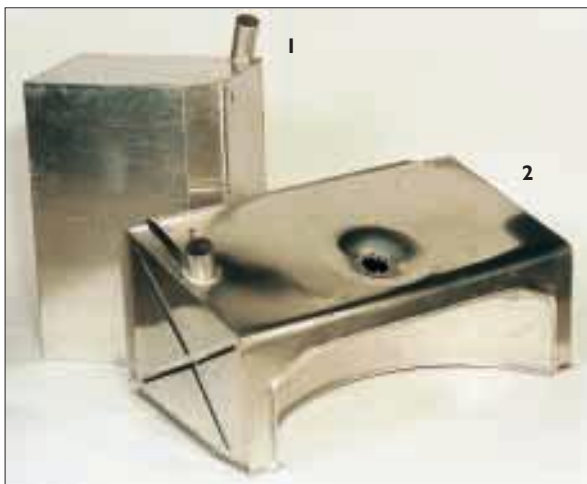

FUEL TANK FABRICATION SERVICE

1. Foam filled or baffled any size or shape to your requirements.

Part No. **ENQUIRE**

2. Alloy 120 fuel tanks to fit as per standard steel type but half the weight.

Part No. **C3618/1A (OTS/FHC)**
C6765A (DHC)

2a. Alloy 140/150 fuel tank as above.

Part No. **C14403/A**



FUEL

Right:

3. Le Mans style filler cap 3/4 inch inside diameter as fitted to C and D types with correct roller catch.

Part No. **FC1**

4. 2 inch fuel filler hose available in any length (price is per foot).

Part No. **BD4368**

5. Filler neck and flange to suit Le Mans cap and 2 inch filler hose, complete with mounting gasket.

Part No. **FC2**

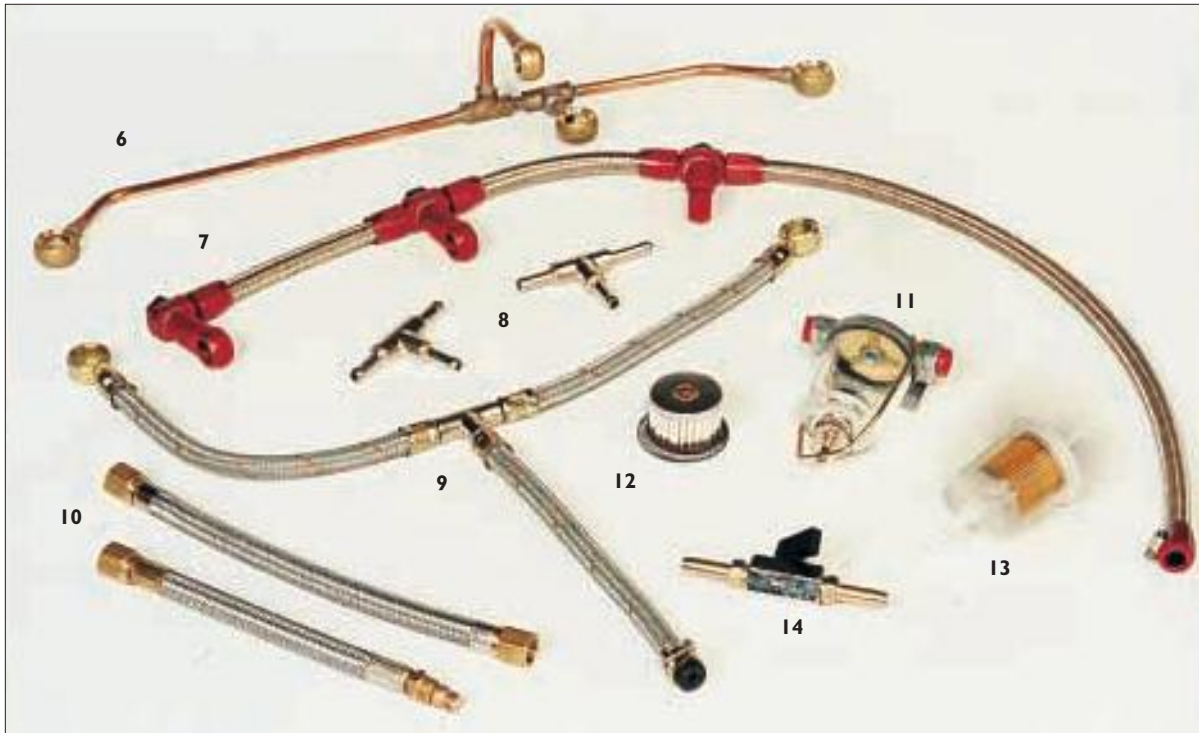

Above:

6. Fuel feed rail for 150 'S' cars. As original or available for any combination of carburetters.

Part No. **CI5283**

7. Triple Weber fuel feed, in stainless overbraid with all alloy fittings.

Part No. **WFF1**

8. Fuel feed 'Tee' piece to take 3/8 inch fuel pipe.

Part No. **ABF170**

9. Flexible fuel feed to carburetters. Again to any customer requirements. Made in-house.

Part No. **FFF1**

10. Fuel pump joining flexible hoses as original on XK150 'S' cars with twin SU pumps.

Part No. **CI4492 - filter hose**

CI4271 - pump hose, rear

11. Glass fuel bowl and filter assembly. As original for 150 'S' cars, but a period fitting for any XK.

Part No. **CI3681**

12. A paper replaceable filter for above. Stops even the finest dirt.

Part No. **C28080**

13. Inline fuel filter to suit 3/8 inch fuel hose.

Part No. **ILF**

14. Inline fuel shut-off valve. A very useful addition to any car or safety conscious owner.

Part No. **FST100**

Below:

15. Facet fuel pump. Suitable for any SU or Weber combination, road or race specification. Complete kit with mountings, adapters and a spare washable filter.

Part No. **FACET/NEG**





COOLING

You just might salvage one of the original copper and brass 'works of art' radiator that cooled the XK. But why haunt the graveyards when off-the-shelf we can supply you with an alloy fabricated copy of the original design that's less than half the weight and a conservative 20 per cent more efficient. With a polished header tank and all the right fittings of the original. Plus the all-important but unglamorous 'back room bits' like hoses.

5



1. Alloy fabricated radiators, superb copies of the original designs but less than half the weight and up to 20 per cent more efficient than the copper and brass construction. Polished tanks with all the right fittings as per the original.

Part No. **XK120** all **AR1**

XK140 late type **AR2**

XK150 all **AR3**

1a. Superstat Thermostat, the correct 72° bypass closing thermostat. Makes sure all the water passes through the radiator when the thermostat is open.



Part No. **C373IS**



COOLING



Left:

2. XK water expansion tank. A great idea that really works well. No more water loss. Allows extra water capacity. Simple to fit in less than one hour. Complete with all necessary parts (made in alloy).

Part No. **HT1A (120/140 EARLY)**
HT2A (140 LATE/150)

3. Kenlowe fan kit. A well tried and tested electric fan kit with adjustable thermostat control.

Part No. **KEN**

Right:

4. Oil cooler kit. A complete bolt-on kit available to suit all XK applications. Includes all fittings for easy installation with no welding or cobbling necessary.

Part No. **XK120/140 OCK1**
XK150 OCK2

Below:

5. Silicone water hose sets. The latest technology for radiator and heater hoses, triple layer hand woven. Will withstand extreme conditions and last a very long time. Suitable for road, rally or race specification.

Note: In smooth black finish.

Part No. **XK120 SHK120**
XK140 SHK140
XK150 SHK150



Below:

6. XK150 fan blade. Correct 12 blade construction as original.

Part No. **C12391**

7. XK140 8 blade alloy fan. Again correct for all 140's.

Part No. **C7615**

8. XK120 6 blade fan for later cars after engine No. W5465.

Part No. **C6747**

9. XK120 cast alloy 5 blade fan for early engines before engine No. W5465.

Part No. **C2231**

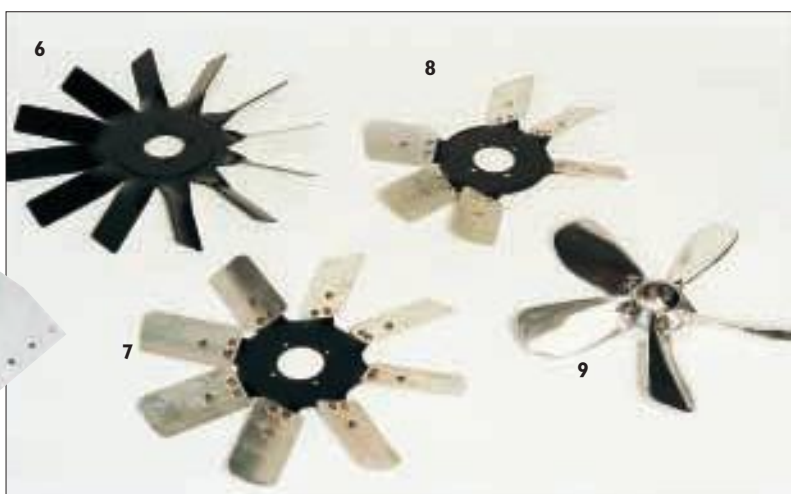

Above:

10. Steel sump guard. Correct copy of original factory part. A 'must' for serious rallying.

Part No. **XK120 C5106**
XK140 & XK150 C13078

PARTS HOTLINE
01676 541980
FAX: 01676 542427



BRAKES

To say that the earliest XK braking systems were unsafe wouldn't be strictly true. It's just that modern technology has come on a bundle since the last of the marque shimmied off the line at Coventry. We can now update the front end of any XK with disc brakes that are 100 per cent more efficient than the XK150 Dunlop system. And work similar magic at the rear end too.

6



1. Front disc brake conversion to update the front of any XK to a superior system with over 100 per cent more braking efficiency than the XK150 Dunlop system. Simple bolt-on kit to original suspension. Includes all fittings, no drilling or welding needed. To suit all XK 120/140/150.

Note: 120/140 will need XK150 front hubs to complete the conversion.

Part No. **FDK11 (120/140)**
FDK10S (150)

3 pot conversion using existing standard 150 mounting plates.



BRAKES



Left:

2. Rear disc conversion kit. A complete kit to include all necessary components to change drum brake cars to disc or to uprate any XK150. Over 60 per cent larger pad area than the original Dunlop system. To fit Salisbury rear axles only.

Note: Two handbrake cable brackets to weld onto 120/140 rear axle (included in kit).

Part No. **FDK12**



Left:

3. Remote servo unit for assisting pedal pressure. Simple inline type servo if you need a softer pedal feel.

Part No. **RBS1**

4. NEW uprated brake shoes lined with Ferodo heavy duty, high temperature material.

Part No. (per set of 4) **35130CE**

5. A replacement XK120 tandem master cylinder using modern trouble-free internals. Simple but very effective. Suitable for disc brake cars also.

Part No. **C6712RE**

6. Competition brake pads available in varying standards of material. Road, rally or full race specification. For use with FDK10 or 11 disc conversion kits only.

Part No. **CBP**

7. Stainless covered Teflon brake hoses. Available to suit all types of brake and clutch system, or made in-house to customers own specification.

Part No. **BHS1 (120/140 SET)**

Part No. **BHS2 (150 SET)**

Below:

9. Full race or fast road disc brake conversions. Again for simple 'bolt-on bolt-off', home assembly. Using 4 piston type alloy callipers and ventilated discs. Included are all necessary mounting hardware and road/rally specification pads.

Part No. **FDK11R**



Below:

8. Fast road/rally brake kit. The best quality kit, with four piston alloy callipers, cross drilled discs and M1144 pads. Includes all parts to fit 120/140 conversion from drums as pictured.

Also available as kit for XK150 without the need to change hubs. This kit will be the 'unfair advantage'!

Part No. **FDK11A**



PARTS HOTLINE

01676 541980

FAX: 01676 542427



SUSPENSION, WHEELS, TYRES & STEERING

7

Wire wheels, knock-off spinners, crossplys and performance tyres. Yours once again thanks to our policy of supplying the original wherever legal and feasible. And where that isn't possible then we uprate the original spec using modern methods and materials; like torsion bars made of aircraft steel, rear leaf springs that are 25 per cent stronger than the original and a gas damper system that's simply the optimum XK shock absorber.



1. Torsion bars, new uprated road/rally specification made of S99 aircraft steel.

Note: Only sold as pairs.

Part No. **C5719/20SS**

2. Front anti-roll bar 7/8 inch diameter for, again, road or rally use. The most effective modification you could make. Also 1 inch diameter for full race use; to special order.

Part No. **C7220/I**

3. Front anti-roll bar. Diameter as per original special equipment specification for 120/140. Suitable for normal road use.

Part No. **C7220**



SUSPENSION, WHEELS, TYRES & STEERING



Left:

4. Fully adjustable anti-roll bar. Another development from our race research programme. 7/8" (22mm) diameter bar with adjustable 'Rose' joint link assembly. Polyurethane bushes and all hardware to fit are included in this excellent value kit.

Part No. **C7220/IA**

Below:

5. Front wishbone polyurethane suspension bushes. A stainless steel inner sleeve acts as a bearing surface for the polyurethane outer bush. For a stiffer suspension but a more precise steering feel without a harsh ride. Sold as a 16 piece car set.

Part No. **POLY 1**

Also a kit available for anti-roll bar (10 piece set).

Part No. **POLY 2**



Above:

6. Telescopic rear damper conversion for all XK120's. Includes upper chassis brackets, lower spring/shock mountings and new longer U bolts.

Note: The top mountings have to be welded in place.

Part No. **SAC120**

7. Spax adjustable shock absorbers. Full range in stock for 120/140/150.

Part No. **SPA1 - front 120**
SPA2 - front 140/150
SPA3 - rear

8. Koni shock absorbers. Also stocked for the standard range.

Part No. **KONI - front 120**
KON2 - 140/150 - front
KON3 - rear

Below:

9. Up-rated road/rally specification rear leaf springs. 25 per cent stronger than the original.

Part No. **C5721 for 120/140**
Part No. **C14476 for 150**

10. Leather spring gaiters as fitted originally to protect from the elements and keep the grease in.

Part No. **C3877/8**

11. Bolt-on spring stiffener kit, to aid standard springs when the car is being used on rallies or hill climbs. 15 minutes to fit.

Part No. **RSKI**

Below:

12. Revised anti-tramp bar kit. Developed from our competitive XK120 car, this kit has fully adjustable 'Rose' joint units that can be altered while mounted in position.

Part No. **TBK100**

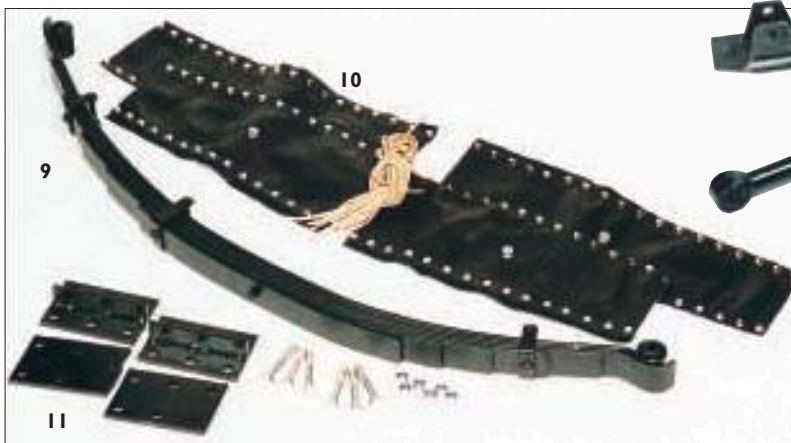

PARTS HOTLINE
01676 541980
FAX: 01676 542427

SUSPENSION, WHEELS, TYRES & STEERING



Left:

13. Chrome 16 inch 60 spoke wire wheel. As fitted originally to XK150 and 150 'S' cars, suitable for all XK's.

Note: Stainless steel spokes with two year guarantee.

Part No. **C12436**

14. Painted 16 inch 60 spoke wire wheel. As above but in silver enamel.

Note: Both of the above wheels are 5 inch wide, will accept 600 x 16 Dunlop racing tyre etc.

Part No. **C14023**

15. Special alloy rimmed 16 inch 54 spoke wheel, correct copy of original C type racing wheel. Polished rim, chrome spokes and centre hub.

Part No. **C6838CA**

Right:

16. Replica 'Dunlop' wheel. Light alloy 6" x 15" wheel. One piece casting, to fit standard splined hubs for all XK models. Chromed centre hub and bolts. Similar to 1950s 'D' Type specification.

Part No. **AWS4** (4 wheels with centre hubs)

TES4 (4 three-eared spinners)



16

Below:

17. Power steering conversion for XK140/150. Available for RHD or LHD. All parts and instructions. Alternator does mean conversion to negative earth system. Fitting by specialist workshop is strongly recommended.

Part No. 140 RHD **PSK3** 140 LHD **PSK4** 150 RHD **PSK5** 150 LHD **PSK6**



17



18 19 20 21

Left:

18. 'Avon' Turbo steel radial tyre 185 x 16 speed rated to VR spec.

Part No. **AVON**

19. 'Pirelli' Cinturato radial tyre 185 x 16 speed rated to VR spec.

Part No. **CINT**

20. Michelin X radial tyre 185 x 16 speed rated to SR spec.

Part No. **MICH**

21. Dunlop Roadspeed RS5 crossply tyre as originally fitted when new. 600 x 16 size.

Part No. **C3760**

PARTS HOTLINE
01676 541980
FAX: 01676 542427

7



ELECTRICAL

Long gone are the days when Lucas was truly 'King of the Road'. The famous Great King Street factory is flatter than a six-volt battery. Yet on our shelves the lion, the wheel and the flame still reign supreme. Faithful reproductions of the original 'windtone' horns, distributors, sports coils, battery isolator switches - all electrical technology of the XK heyday.



1. 'Mallory' twin contact point distributor. Very high quality rally or race specification unit. Also with vac advance.

Part No. **MALLORY**

Note: Mallory distributor service items also in stock. Please call for part numbers.

2. Battery isolator switch. Period Lucas part for safety and security.

Part No. **IB2804**

3. Competition battery cut-off switch with removable key for extra safety.

Part No. **BC05I**

4. Performance ignition lead, correct period yellow with black stripe and copper core. The right finishing touch.

Part No. **HPL**

5. NGK high performance plug caps, water tight seals for lead and plug.

Part No. **LB05F**

6. NGK high performance spark plugs. For extreme conditions rely on the best plug.

Part No. **NGK**



ELECTRICAL

Right:

7. Lucas sports coil. High output coil, but note that the high tension output is for push-on type connector.

Part No. **LSCI**

8. Lucas distributors - all specifications in stock, from standard to full race.

Part No. **ENQUIRE**

9. Battery cut-off switch to full F.I.A. specification.

Part No. **BCOS2**

10. Alloy plug-lead spacer block to fit on cam cover.

Part No. **PLBIA**

11. Solid state electronic ignition system. Fit in 15 minutes with no more points adjusting ever again. So simple but very effective. *Please state distributor model and positive or negative earth.*

Part No. **ENQUIRE**

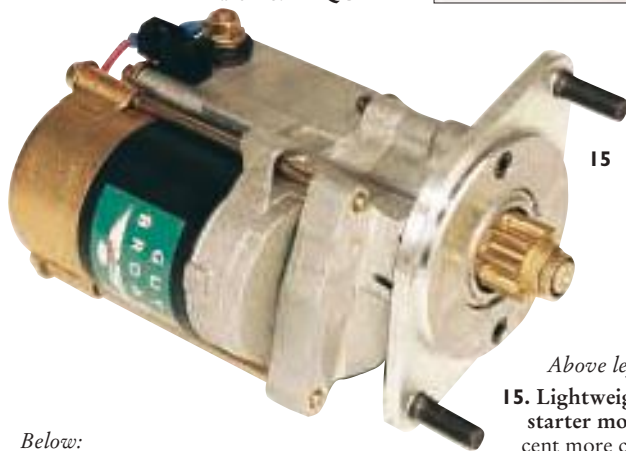

Above left:

15. Lightweight high output starter motor with 20 per cent more cranking power. Draws less current and weighs less than half the original unit.

(Need we say more). For positive or negative earth systems.

Part No. **RSM100**

Below:

12. Lucas style XK120 horns. Correct reproduction of the original 'windtone' horn. Sold in pairs of high and low note.

Part No. **C2827/8**

13. Lucas original horns for the XK140/150 range. A rare item in cast alloy. We restore originals when we can find them, but expensive!!

Part No. **C5226 High**
C5227 Low

14. Lucas 1960's style horns as fitted to E type and MK2. A very suitable replacement to the above and available in high and low note pairs, for an authentic look and sound - at a very reasonable price.

Part No. **HRI**



Above:

17. 6 volt rubber-cased battery. Correct XK type for 140 FHC and all 150's (two per car).

Part No. **C9150**

18. 12 volt rubber-cased battery for 140 DHC/OTS.

Part No. **C2608**

19. 6 volt rubber-cased battery. Correct for all XK120's with extensions to fit the bakelite covers and hooks as original. Two per car.

Part No. **C2767**

Below:

16. Battery cable sets. We stock the full range of XK variations, but can, of course, make up sets to suit customers own requirements.

Part No. **ENQUIRE**



PARTS HOTLINE
01676 541980
FAX: 01676 542427

ELECTRICAL



Left:

20. Smiths and Lucas instrument restoration service. We stock all types ready for exchange. Even speedos in KPH. We also calibrate to customers individual cars.

Part No. **ENQUIRE**

21. Time clock restoration service. As original or to modern solid-state type internals, for total reliability.

Part No. **ENQUIRE**

22. Original dash board restoration service either to customers own wood components or complete car sets. New. Absolute concours finish guaranteed.

Part No. **ENQUIRE**

Right:

23. Lucas SFT 700 type fog light. 7 inch fog light assembly as fitted to XK120.

Part No. **C2988**

24. As above unit but SLR 700 spot light with clear non-fluted lens.

Part No. **SLR700**

25. Lucas SFT 576 fog light as fitted to special equipment XK140/150 cars.

Part No. **SFT576**

26. Spot light lens to convert fog to spot for 576 unit.

Part No. **5296S**

27. Chrome stone guard assembly for 7 inch type fog lights. Correct period part for rally use.

Part No. **FSG7**

28. As above for the 5 1/2 inch 576 type light unit.

Part No. **FSG575**



8



Left:

29. Chrome mounting bracket for fitting SLR 700 type spot/fog light to XK120 bumper mounting studs. Sold in pairs.

Part No. **C2985/6**

30. Complete fog light fitting kit as per original for 576 type units on XK140/150 including chrome spacers, grommets in valances and under mounting brackets. Sold as car set for two lights.

Part No. **FLKI**

PARTS HOTLINE
01676 541980
FAX: 01676 542427



INTERIOR & EXTERIOR FITTINGS

9

The true beauty of any XK is more than skin-deep, but that's no excuse for prizing performance before the aesthetic pleasure of an immaculate and authentic turnout. The right seats, period mirrors, a wood-rim steering wheel - they all express your pride in the marque. And effective yet unobtrusive safety harnesses will show a proper concern for personal safety.



1. Clubman-style 3 point safety harnesses. In silver material specially supplied to our specifications. Simple to fit. Will suit any interior colour scheme. Complete with necessary eye bolts for easy fitting.

Note: The harnesses can be unclipped from the eye bolts when not needed.

Part No. **LUKE**



INTERIOR & EXTERIOR FITTINGS



Left:

2. Competition style bucket seat as fitted to XK's. Aluminium shell. NOT trimmed.

Part No. **BD5893**

2a. As above but in reinforced fibreglass. NOT trimmed.

Part No. **BD5893F**

3. Tilting bucket seat made in steel for rigid strength. This seat will allow the use of hood frames and access to battery areas etc. Will fit all types of XK. Price is per seat including chrome pivot pins.

Part No. **BD5893ST**

Note: All the above can be trimmed to the customers choice. Please call for pricing and delivery times.



Above:

4. Four spoke wood-rim steering wheel 16 inch diameter. A period-looking wheel that suits any XK interior and can be used with original horn push assembly.

Part No. **MOT2**

5. Steering wheel boss to suit above wheel so that original horn push unit can be used.

Part No. **XK120 - MOT3P and MOT5P**
XK140/150 - MOT4P

Above:

6. Static 3 point seat belts. Period 1950's style with chrome aircraft style buckles, black webbing and plated fittings. Will suit most models. Price is for a kit consisting of 2 sets of belts and all fixings.

Part No. **SBI**

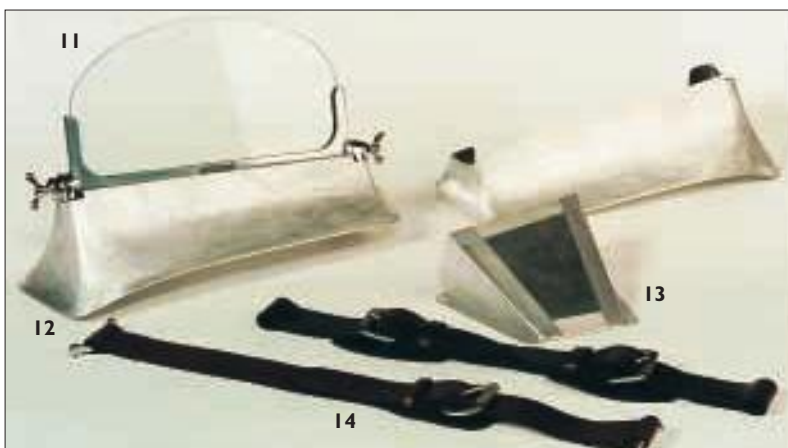

Above:

11. 'Brooklands' Aeroscreen. A super copy of the 1950's racing windscreens - polished alloy frame and chrome fittings.

Part No. **BD4289**

12. Aeroscreen cowlings. A correct reproduction of the parts fitted to factory racing XK's. In alloy, ready for painting.

Part No. **BD4299 and BD4300**

13. Alloy mirror cowl to suit the cowlings. Available for RHD or LHD.

Part No. **MC1 - RHD**
MC2 - LHD

14. Leather bonnet strap, as fitted to the Le Mans cars and works rally cars of the 1950's, with chrome fittings included. Available in single or double buckle fittings.

Part No. **Single Buckle BSI**
Double Buckle BS2

Above:

7. 1950's alloy racing mirror, a copy of the 'Raydot' mirror.

Part No. **LAM**

8. Correct XK 'Lucas' style wing mirror LH or RH chrome arm and stainless steel mirror backing.

Part No. **LH - WX1906**
RH - WX1905

9. Bullet type wing/door mirror 1960's style chrome two bolt fitting.

Part No. **BDM**

10. Quarter light door frame mirror, chrome and stainless steel. No drilling necessary - very useful on all Coupés to catch that 'blind spot'.

Part No. **QLM**



ACCESSORIES

Authentic replica accessories are part and parcel of any well-equipped XK workshop. Never short change on accessories. Always do the very best by your car. We've a wing protector to safeguard the mirror-like finish of your car. Reproduction tool rolls; wire wheel cleaning brushes; chain tensioning tools - even a wooden spinner-saver-cover for you to bash! And to add that final touch of classic elegance, there's a complete range of replica ID plates and decals. Yet another exclusive from Guy Broad Parts.

10



1. Padded Jaguar wing protector. Black vinyl with sponge type backing to withstand dents and scratches made by tools and fixings when working in the engine bay. Also very useful all around the car when doing any routine servicing. We use them in our workshop! Black with white decals only.

Part No. **WP100**



ACCESSORIES



Above:

2. Reproduction of original tool rolls. In correct heavyweight material for XK120 and black lined hardura for XK140/150. Part No. **XK120 C2882**

Note: tools not included.

XK140 C5578

3. Correct copper and hide 'Thor' hammer as fitted for all wire-wheel cars.

Part No. **C992**

We keep a wide range of reproduction tools. Please ask for our latest stock details.

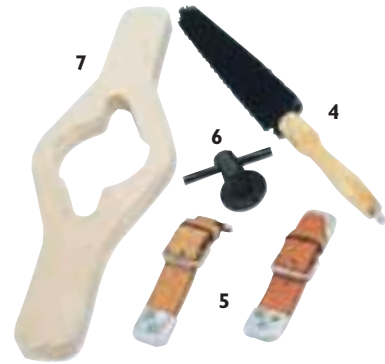

Above:

4. Wire wheel cleaning brush.

Part No. **VWB**

5. Leather boot and bonnet straps. Approximately 5" long including fittings. Price is for two straps.

Part No. **LBS**

6. Chain tensioning tool. To suit all XK engines. Adjust the rattle out of those chains!

Part No. **TCTI**

7. Spinner saver tool. A wooden cover to bash, instead of damaging your chrome spinner!

Part No. **STI**



Left:

8. A complete Fire Extinguisher kit, including a Clubman specification 2.25 kg unit and fitting cage, and a set of pipes and cables to adapt for a fully plumbed-in system. Easy snap-together piping makes this the most simple kit on the market. This means the danger points can be directly extinguished without opening the bonnet or boot lid.

Part No. **FE**



Left:

9. As original tyre pump. Fitted new to all XK120's.

Part No. **C997**

10. As original XK jack by 'Smiths Jacking Systems'. Correct colour and detail.

Part No. **C2953**

11. Correct copy of jack ratchet fitted to all XK's.

Part No. **C2954**

12. 16 inch tyre inner tubes - high quality and correct for all XK high speed tyres.

Part No. **C5636**

13. 16 inch wheel rim band - to stop spokes puncturing the inner tube, as fitted originally.

Part No. **C5636B**

As stockists of Castrol Classic Oils, we can supply a complete range as originally used - when XK's were new!

Below:

14. Reproduction oil-pouring cans, very useful and look good in any garage. Small. Medium. Large.

Part No. **J115 per set of 3**

15. Castrol Classic Engine Oil. We have found that the original formula oils have a marked effect on improving oil pressure and temperature. We use only the best in our workshop.

Part No. **(XL30) 1924 (gallon)**
(XL40) 1926 (gallon)

16. EP90 Gear Oil for axles - again as the original and still the best.

Part No. **1840 per litre**

17. LM grease. Suitable for just about everything that needs greasing.

Part No. **1631**

Note: oils cannot be sent by mail and must be collected.



ACCESSORIES



Left:

18. Accessory indicator kit. For early XK120 roadsters. Very high quality light units, solid machined and chrome plated in a 50s style. High intensity bulbs, dash switch with internal flashing bulb, low voltage relay, mounting brackets and cable. No drilling of bodywork necessary.

Part No. **AIK**



Below:

19. Electric washer conversion. To convert all vacuum systems. Switch fits original dash hole and looks correct. You can also hide the pump under dash to fool the experts. All parts included.

Part No. **EWK**



Below:

20. Electronic ignition. Fitted in 15 minutes. All hidden inside original cap. Exclusive to Guy Broad Parts. For XK120/140/150 with positive earth system. Also available for negative conversions.

Part No. 120/140 pos. earth **EIK1P**

Part No. 120/140 neg. earth **EIK1N**

Part No. 150 pos. earth **EIK2P**

Part No. 150 neg. earth **EIK2N**



10

Right:

21. A complete range of chassis ID plates and decals to finish off any correct restoration. We reproduce the chassis plates and 'heater caution' plate exactly as original in acid etching and nickel-plated where it appeared originally. Another exclusive for Guy Broad Parts!

Part No. **ENQUIRE**



How To ORDER

- AND THE 'SMALL PRINT'

It is Guy Broad policy to offer the widest range of parts available, at competitive prices, backed by a friendly and helpful service. If you have any problem with any item you buy from us, then we will do our best to put things right - just phone and ask to speak to a member of our sales staff.

We welcome personal visitors, any weekday between 9.00am and 5.30pm (09.00 to 17.30 for 24-hour clock watchers, but remember it's UK local time if you live in New Zealand).

But of course our speciality is Mail Order. You can order by post - or by phone or fax between 9.00am and 5.30pm:

PARTS HOTLINE
01676 541980
FAX: 01676 542427

Payment is normally by any major credit card (except AMEX) or by cheque which must be sent first ie before goods leave the premises. Bank Transfer is also available by arrangement.

Exchange units. If you are based in the UK, then certain items are available on an exchange basis - you return your old unit to us for reconditioning in exchange for one already reconditioned.

If you can't let us have your old unit at the time of ordering then we will ask for a **deposit surcharge**, these surcharges are clearly identified in our price list. As soon as we receive your old unit then the surcharge will be refunded in full - provided the unit is capable of reconditioning, of course.

If you are ordering an exchange for delivery **outside the UK** then we must receive an old unit capable of reconditioning, before we can forward the replacement.

Some units are so rare that we cannot offer another in exchange but have to recondition your own, if possible.

We hope all this is crystal clear - if not please phone!

Overseas orders. When ordering from outside the UK, please ensure you enclose full details of your car - such as the engine and chassis numbers, whether left hand or right hand drive and year of manufacture. Goods will be sent 'all carriage charges forward' unless pre-paid.

Please remember all overseas orders are subject to local import duty and customs clearance, which you will have to pay at the point of entry.

Export quotations. You can ask for a quotation by fax, email, letter or phone. We endeavour to always answer by return. There seems to be some confusion about the word 'quotation' - if we send a quote it is **not an invoice** it is only an indication to you of your price.

Charges for Packing and Carriage. We will always use the most economical method available to send your goods to you. For urgent orders, please phone our sales staff. They will be happy to advise you.

Back orders. We keep at least 12,000 items in stock at any one time but now and then we may run out of a particular item in the catalogue. If we cannot meet your order within 14 days of receipt then we will consider it cancelled, unless you state otherwise. Naturally, we will refund in full any money you may have paid before the order was cancelled.

Warranty. All parts are fully warranted against defects in materials and workmanship. In most cases the warranty will not cover labour, failure of a related component, failure resulting from faulty installation or misuse. Liability would not exceed the cost of the original component. During the warranty period (which is usually 12 months) please contact us immediately if any problem should occur; we will then advise you on the best course of action.

A copy of the purchase invoice must accompany all claims under warranty.

Terms and Conditions of Sale

1. Payment must be made for all orders prior to despatch unless other arrangements have been made.
2. All parts supplied carry manufacturer's warranty, this does not affect your statutory rights. The invoice number must be supplied with any claim regarding faulty parts.
3. All mail order parts are insured by us or by our appointed carrier. Claims of shortage or damage must be notified within three days of receipt of the consignment.
4. We are unable to replace goods damaged in transit if they have been signed for as 'goods in good condition'. So do not sign for the goods you receive until you have checked their condition.
5. Placement of an order will be taken as acceptance of the foregoing conditions.

Every effort is made to ensure the accuracy of the particulars contained in this catalogue - but Guy Broad Parts and any manufacturing company will not, in any circumstances, be held liable for any inaccuracies or the consequences thereof.



Polished, balanced, tuned, up-rated, modified - BroadSport performance parts are in a class of their own.

But then they come from a pedigree stable. BroadSport parts have been designed, developed, tried, fully tested and endorsed by our experts under racing conditions, culminating in the runaway victory of the 'BroadSport 120' in the XK Jaguar 50th Anniversary Classic race at Donington in June 1998.

And in the following year, the renowned BroadSport XK200, nicknamed the 'Bubble', achieved a record speed of 183.92 mph to become the world's fastest XK.

BroadSport performance parts – they're going - fast!

fast cats



on-line



www.guybroad.co.uk

Never has a mouse been more compatible with a big cat!

Click onto the Guy Broad website and you'll discover all the very latest from the biggest name in Jaguar XK classic parts.

Source thousands of parts and accessories from stock through our easy-to-use on-line parts catalogues. Visit our Newsbox and check out what's new from Guy Broad and our world-wide customer base. Be a part of it and share your news and comments with other XK enthusiasts.

Find out more about the Guy Broad workshops and exciting new-build cars. Read up on Guy Broad's motor sport achievements and the BroadSport competitive edge.

Buying or selling? Don't miss the XK Sales & Wants section. Regularly updated with lots of interesting race/rally cars, restoration projects, parts and memorabilia, this is your first point of contact for everything XK.

The Guy Broad website is your window on the world of the Jaguar XK. Indulge your passion with links to other great sites devoted to this impeccable sporting classic.

Road, race, rally, lifestyle or commuter motoring, it's all here!

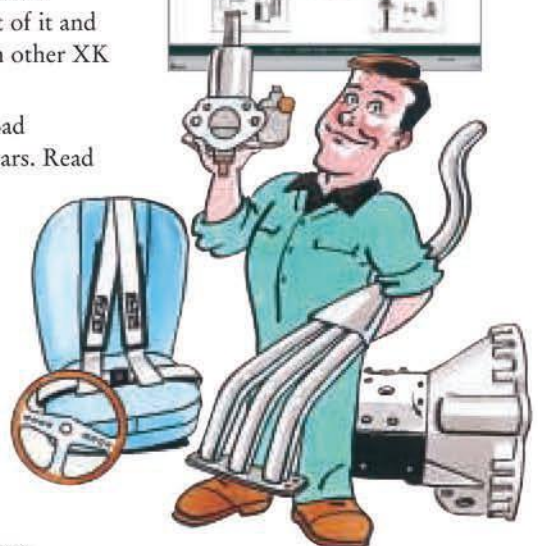

HOME OF THE WORLD'S FASTEST XK



JAGUAR XK 120 · 140 · 150 PARTS SPECIALISTS

BROADACRES, WALL HILL ROAD, CORLEY, COVENTRY CV7 8AD TEL: 01676 541980 FAX: 01676 542427

E-MAIL: sales@guybroad.co.uk WEB: www.guybroad.co.uk